

Coating Accessories

4M Electro-Optics Co.,Ltd

Contents

1. Material Comparison	16-17
2. Crucibles	18
3. Evaporation Boats	19
4. Filaments	19

Materials overview

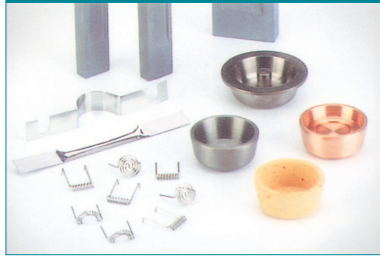

Material	Purity	Forms			Dimensions	Colour(In House)	Melting Point °C	Density g/cc, 300K	Risk and safety Indication	Remarks
		Crucibles	Boats	Filaments						
Cu	99.97%	•			Upon request	Brown Red	1084	8.96	Not poisonous or toxic	Easily oxidized
Mo	99.50%-99.99%	•	•		Upon request	White Grey	2630	10.22	Not poisonous or toxic	Chemically stable and brittle
W	99.50%-99.99%	•	•	•	Upon request	White Grey	3407	19.35	Not poisonous or toxic	Chemically stable and brittle
Ta	99.50%-99.99%	•	•		Upon request	Black Grey	2996	16.65	Not poisonous or toxic	Chemically stable
C	99.99%	•			Upon request	Black	3850	2.26	Not poisonous or toxic	
Nb	99.50%-99.99%	•	•		Upon request	Stainless Grey	2468	8.57	Not poisonous or toxic	
Al ₂ O ₃	99.50%	•	•		Upon request	White	2020	3.98	Not poisonous or toxic	Brittle
BN	99.50%	•	•		Upon request	White	3000	2.80-3.20	Not poisonous or toxic	
SiO ₂	99.99%	•			Upon request	Transparent	1710	2.32	Not poisonous or toxic	Brittle

Crucibles

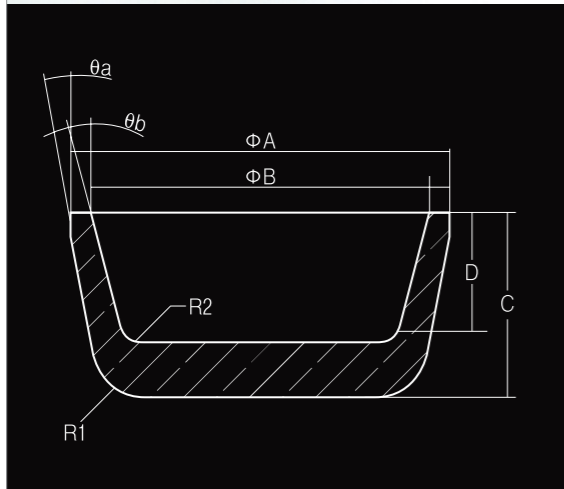

Customized crucibles

ΦA :	[mm]
ΦB :	[mm]
C:	[mm]
D:	[mm]
θa :	[mm]
θb :	[mm]
R1:	[mm]
R2:	[mm]

Evaporation Boats

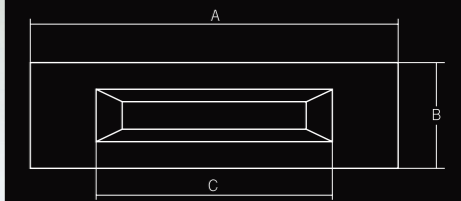
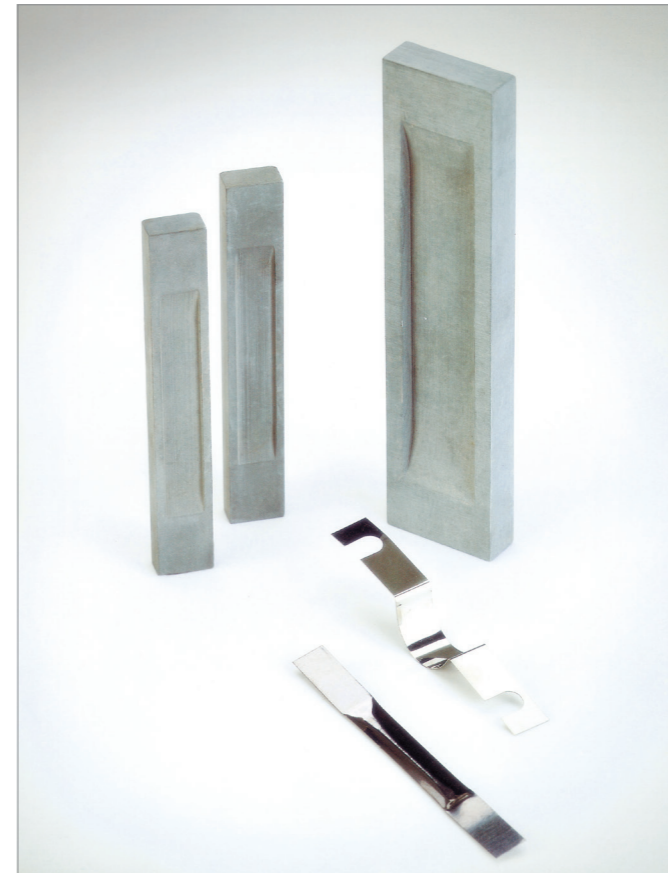

Customized evaporation boats

A:	[mm]
B:	[mm]
C:	[mm]
Sheet thickness:	[mm]
Cubage:	[mm]

Filaments

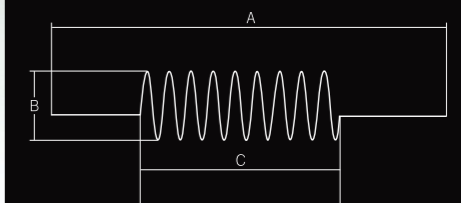

Customized filaments

A:	[mm]
B:	[mm]
C:	[mm]
Wires Diameter:	[mm]
Windings:	[mm]